

GAS ONLY
DUE TO WEIGHT REQUIREMENTS

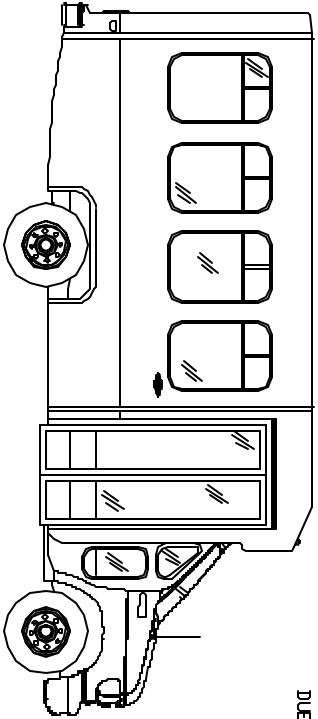

- NOTES:
1. = 30" x 48" WHEELCHAIR PLACEMENT.
 2. WHEELCHAIR DOOR CLEAR OPENING IS 45" x 68".
 3. SIDE WINDOWS: 24" X 36" TOP T-SLIDER.
 4. - EMERGENCY WINDOW.
 5. FLOOR PLAN IS SUBJECT TO CHANGE PENDING WEIGHT & CG CALCULATIONS OF OPTIONS AND CHASSIS REQUESTED.

THIS SPECIFICATION IS THE PROPERTY OF DIAMOND COACH CORPORATION AND ANY USE WITHOUT WRITTEN PERMISSION IS PROHIBITED. WE RESERVE THE RIGHT TO MAKE CHANGES WITHOUT NOTICE IN MODELS, EQUIPMENT, SPECIFICATIONS, PRICES, COLORS, MATERIALS AND ALSO TO DISCONTINUE MODELS.

13 PASSENGERS

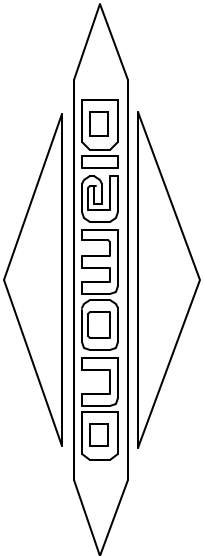

COACH CORPORATION
P.O. BOX 489, 2300 WEST FOURTH STREET
DSWEGD, KANSAS 67356 (620)-795-2191 FAX-4816

TITLE:	2000-B VIP FLOORPLAN
BASIS:	FORD CUTAWAY CHASSIS
DRAWN BY:	W.TUCKER
DATE:	03/25/04
NUMBER:	2001-B-104